

For optimal fluorescence and spectral photometric analysis in the UV/Vis range



Cuvette

4 clear sided

F I R S T C L A S S · B R A N D

Plastic disposable UV-Cuvettes for the UV/Vis range. UV-transparent plastic cuvettes replace fragile glass or quartz cuvettes in many applications. Designed for single use, they eliminate time wasting washing, and the risk of cross-contamination.

- Four optical windows for precise measurements
- Suitable for fluorescence spectroscopy
- Significantly lower costs for use when compared to quartz glass cuvettes
- UV-Cuvettes show minimal autofluorescence
- Will fit most fluorescence photometers
- UV-Cuvettes show very high chemical resistance
- UV-Cuvettes for measurements from 230 nm
- Frosted end for labelling

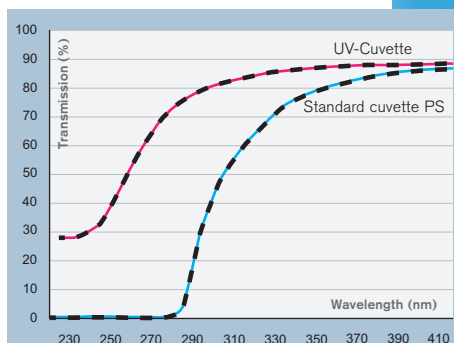

--- rotated by 90°

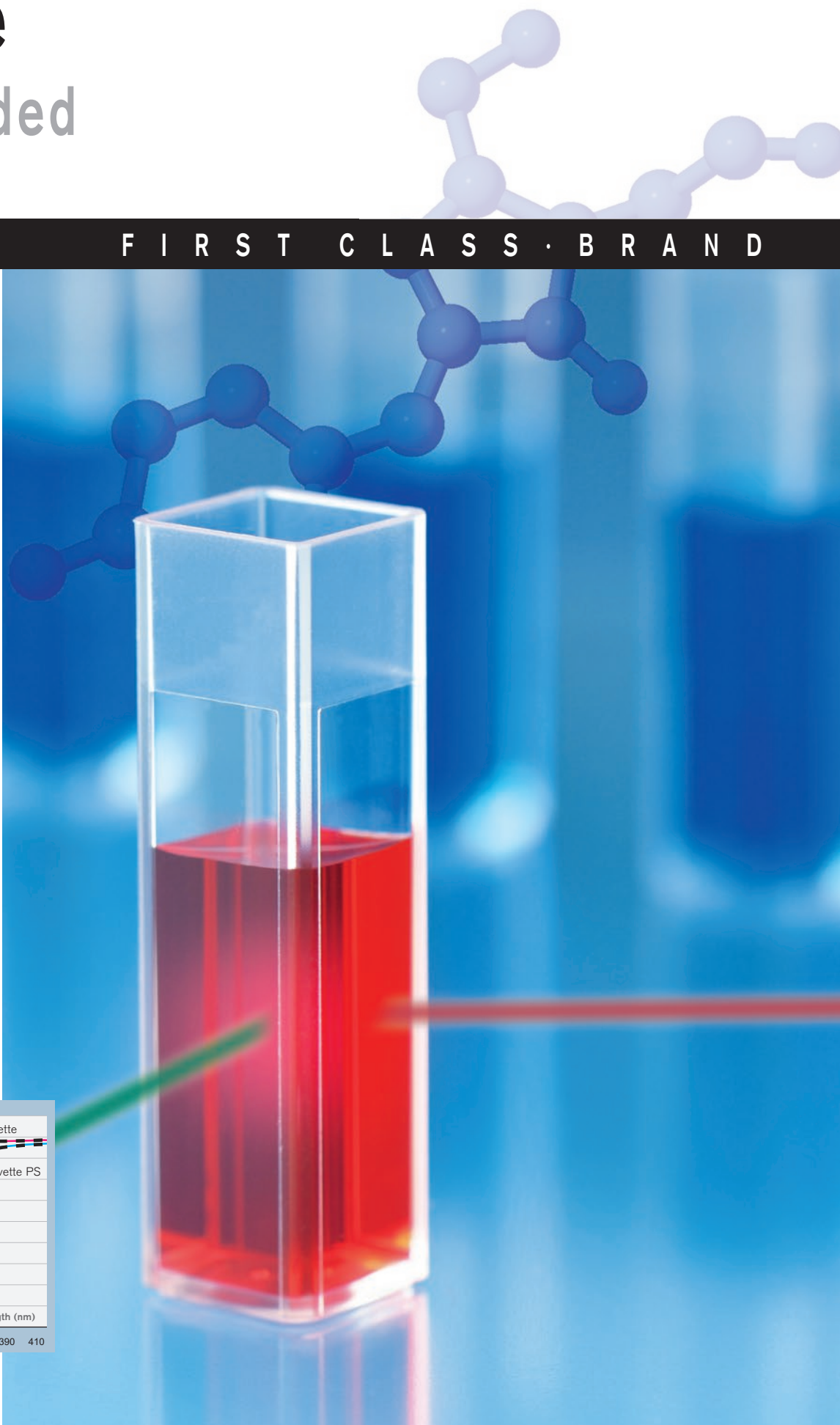

Technical Information

Filling volume:

PS Cuvette: 2.5 - 4.5 ml
UV-Cuvette: 2.5 - 4.5 ml

Dimensions:

Window (W x H): 10 x 35 mm
Light path: 10 mm

Wavelength:

PS Cuvette: 340-900 nm
UV-Cuvette: 230-900 nm

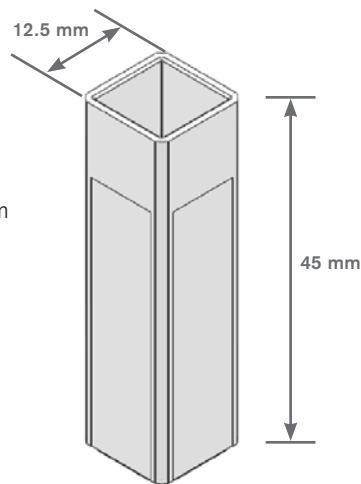

Ordering Data

4 clear sided cuvettes

Description	Pack of	Cat. No.
Cuvette, macro (PS), 4 clear sided	100	7590 30
	500	7590 35
UV-Cuvette, macro, 4 clear sided	100	7591 25
	500	7591 28

Cuvette rack

PP, gray. Holds 16 cuvettes, numbered positions.
L x W x H: 210 x 70 x 38 mm.
Autoclavable (121 °C).
Pack of 1.

Cat. No.	7595 00
----------	---------

Overview Table

Cuvette type	Filling volume		Dimensions window (W x H)	Range of application	Standard deviation in extinction units
	min.	max.			
UV-Cuvette, macro, 4 clear sided	2.5 ml	4.5 ml	10 x 35 mm	230 to 900 nm	240 nm ≤ ± 0.007 300 nm ≤ ± 0.005
Cuvette, macro (PS) 4 clear sided	2.5 ml	4.5 ml	10 x 35 mm	340 to 900 nm	360 nm ≤ ± 0.005

BRAND also manufactures standard macro and semi-micro cuvettes in PS and PMMA. Detailed information on request, or at www.brand.de

Chemical resistance* of plastic cuvettes

Substance	PS	PMMA	UV-Cuvette
Acetic acid, 100%	-	-	+
Acetone	-	-	+
Ammonia	+	+	+
Benzaldehyde	-	-	+
Butanone	-	-	+
Chloroform	-	-	-
Dioxane	-	-	+
DMF	-	-	+
DMSO	-	-	+
Ethyl acetate	-	-	+
Hexane	-	+	-
Hydrochloric acid, 36%	+	-	+
Hydrofluoric acid, 10%	+	+	+
Isopropanol	+	+	+
Nitric acid, 65%	-	-	+
Sodium hydroxide	+	+	+

* Short time resistance, 30 min. Longer term storage of these chemicals should be confirmed by the user. Free samples upon request.

UV-Cuvettes of minimal autofluoreszenz

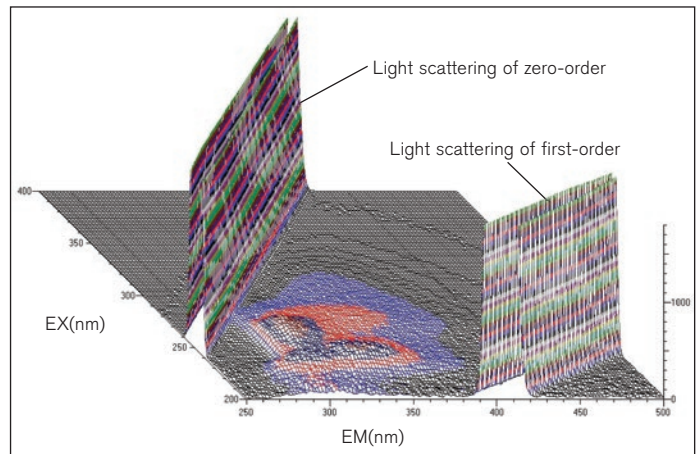

3-D scan from 200 to 400 nm wavelength with Hitachi F -7000 FL-Spectrometer

BRAND®, BRAND. For lab. For life.® and the BRAND word and figurative mark are registered trademarks of BRAND GMBH + CO KG, Germany.

Our technical literature is intended to inform and advise our customers. However, the validity of general empirical values, and of results obtained under test conditions, for specific applications, depends on many factors beyond our control. Please appreciate, therefore, that no claims can be derived from our advice. The user is responsible for checking the appropriateness of the product for any particular application.

California Residents: For more information concerning California Proposition 65, please refer to www.brand.de/calprop65

Subject to technical modification without notice. Errors excepted.

BRAND GMBH + CO KG · P.O. Box 11 55 · 97861 Wertheim · Germany

Tel: +49 9342 808-0 · Fax: +49 9342 808-98000 · E-Mail: info@brand.de · Internet: www.brand.de



Disposable plastic cuvettes for spectrophotometric analyses in the UV/VIS range



UV-Cuvettes

H I G H - T E C H D I S P O S A B L E S

Plastic disposable UV-Cuvettes for the UV/VIS range.

UV-transparent plastic cuvettes replace fragile glass or quartz cuvettes in many applications that were previously beyond the range of plastic cuvettes. Designed for single use, they eliminate time-wasting washing, and the cross-contamination risk associated with washing and reusing cuvettes.

- Ideal for determination of purity and concentration of proteins, DNA and RNA
- Will fit most commercial photometers without need for adapters
- Very high chemical resistance



Disposable cuvettes for the UV/VIS range!

Quality features

- Grouped by mold cavity number
- Light path 10 mm
- Minimal extinction value variation
- Clear, clean optical path
- Recessed windows protect against scratching
- Arrow indicates optical path orientation

What is "grouped by mold cavity number?"

A plastic injection mold with 8 separate cavities can produce 8 cuvettes at a time. Minor dimensional variations between the cavities are unavoidable despite the most advanced technology. This may result in a greater variation of extinction values

between cuvettes from different cavities. Therefore, cuvettes originating from the same cavity are automatically packaged into the same carton (100 resp. 500 cuvettes). For best results, use cuvettes from the same cavity number for each series of analyses.

More advantages

- Two optical surfaces
- High purity through fully automated packaging
- Disposable – therefore: no carry-over of samples
minimized risk of contamination
no cleaning costs



UV-Cuvette micro

Starting from 70 μ l and 230 nm!



- Specially designed for photometric determination of proteins, ssDNA, dsDNA, RNA and oligonucleotides in the UV range
- Ideally suited for measurements at 260 nm, 280 nm and in the visible range
- No need for cleaning, no associated risk of contamination
- Sample volumes as small as 70 μ l are sufficient
- Two different center heights without adapter in most commercial spectrophotometers.
- Individually wrapped UV-Cuvettes micro are free of DNase, DNA and RNase.
- Round caps provide tight seal and allow storage of samples at -20 °C
- Colored caps available for easy sample identification

Specifications of the UV-Cuvette micro

Filling volume:

UV-Cuvette micro 8.5 mm:
70-850 μ l

UV-Cuvette micro 15 mm:
70-550 μ l

Dimensions:

Window (minimum):
2 x 3.5 mm

Light path:
10 mm

Wavelength range:

230-900 nm

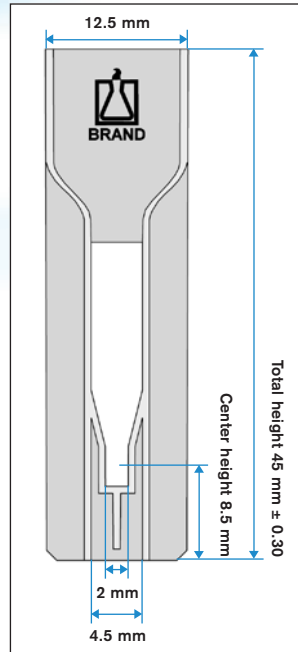

UV-Cuvette micro
c = 8.5 mm

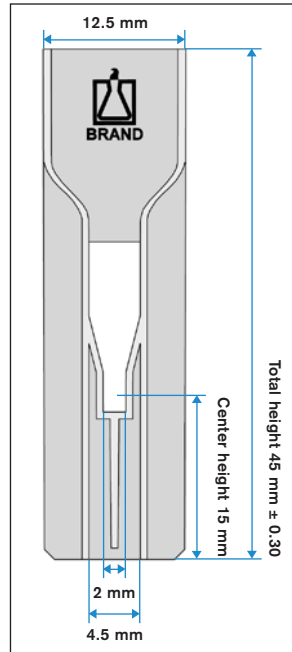

UV-Cuvette micro
c = 15 mm

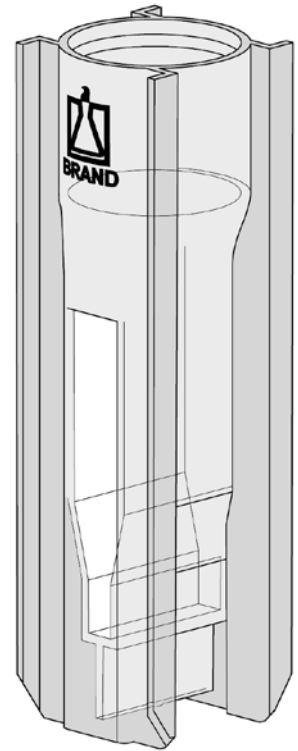

UV-Cuvette macro semi-micro

For applications from 230 to 900 nm

- Ideally suited for determinations in water analysis, chemistry, and in life science applications
- Drastically reduced risk of contamination and lower costs compared to quartz cuvettes
- Usable with most polar solvents, acids and alkalis
- UV-Cuvette semi-micro: Filling volume 1.5 to 3 ml
UV-Cuvette macro: Filling volume 2.5 to 4.5 ml



Technical Information

Overview Table

Cuvette type	Filling volume		Dimensions window (w x h)	Range of application	Standard deviation in extinction units
	min.	max.			
UV-Cuvette micro, z = 8.5	70 µl	850 µl	2 x 3.5 mm (min.)	from 230 to 900 nm	240 nm ≤ ± 0.007 300 nm ≤ ± 0.005
UV-Cuvette micro, z = 15	70 µl	550 µl	2 x 3.5 mm (min.)		
UV-Cuvette macro	2.5 ml	4.5 ml	10 x 35 mm		
UV-Cuvette semi-micro	1.5 ml	3.0 ml	4.5 x 23 mm		

BRAND also manufactures standard macro and semi-micro cuvettes in PS and PMMA. Detailed information on request, or at www.brand.de

Chemical resistance* of plastic cuvettes

Substance	PS	PMMA	UV-Cuvette
Acetic acid, 100%	-	-	+
Acetone	-	-	+
Ammonia	+	+	+
Benzaldehyde	-	-	+
Butanone	-	-	+
Chloroform	-	-	-
Dioxane	-	-	+
DMF	-	-	+
DMSO	-	-	+
Ethyl acetate	-	-	+
Hexane	-	+	-
Hydrochloric acid, 36%	+	-	+
Hydrofluoric acid, 10%	+	+	+
Isopropanol	+	+	+
Nitric acid, 65%	-	-	+
Sodium hydroxide	+	+	+

* Short time resistance, 30 min. Longer-term storage of these chemicals should be confirmed by the user. Request a free sample.

Transmission curves of different cuvettes

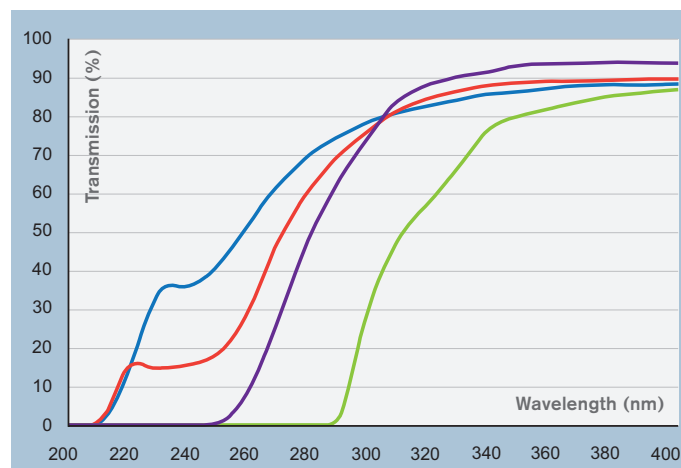

— UV-Cuvette micro — Standard cuvette PMMA
— UV-Cuvette semi-micro/macro — Standard cuvette PS

To achieve reproducible results: Before the actual measurement, always determine the blank value for the cuvette, and determine the linear range of measurement by means of a calibration curve.

Ordering Data

UV-Cuvettes

Description	Pack of	Cat. No.
UV-Cuvette micro, c = 8.5 mm	100	7592 00
	500	7592 10
	single wrapped	100
UV-Cuvette micro, c = 15 mm	100	7592 20
	500	7592 30
	single wrapped	100
UV-Cuvette semi-micro	100	7591 50
UV-Cuvette macro	100	7591 70

Caps UV-Cuvette micro

PE, pack of 100.

Color	Cat. No.
blue	7592 40
yellow	7592 41
green	7592 42
orange	7592 43

Cuvette rack

PP, gray. Holds 16 cuvettes, numbered positions. L x W x H: 210 x 70 x 38 mm. Autoclavable (121 °C). Pack of 1.

Cat. No.	7595 00
----------	---------

BRAND®, BRAND. For lab. For life.® and the BRAND word and figurative mark are registered trademarks of BRAND GMBH + CO KG, Germany.

Our technical literature is intended to inform and advise our customers. However, the validity of general empirical values, and of results obtained under test conditions, for specific applications depends on many factors beyond our control. Please appreciate, therefore, that no claims can be derived from our advice. The user is responsible for checking the appropriateness of the product for any particular application.

California Residents: For more information concerning California Proposition 65, please go to www.brand.de/calprop65

Subject to technical modification without notice. Errors excepted.

BRAND GMBH + CO KG · P.O. Box 11 55 · 97861 Wertheim · Germany
Tel: +49 9342 808-0 · Fax: +49 9342 808-98000 · E-Mail: info@brand.de · Internet: www.brand.de

9945 41 · Printed in Germany · V0818 · WA/0818

