

# 03

## VOLUMETRIC GLASSWARE

---



## DURAN® VOLUMETRIC GLASSWARE

Volume measurement – a routine laboratory procedure. So making long-term quality assurance for the associated instrumentation all the more important, from volumetric flasks to stoppers. From one day to the next, with each analysis.

Made of DURAN® borosilicate glass 3.3, our volumetric flasks, measuring and mixing cylinders, and burettes offer excellent chemical and thermal resistance, something that is above all reflected in the mechanical properties of the glassware. Thanks to exact processing and precisely calibrated scales, they permit the highly accurate determination and measurement of volumes.

DURAN® products are available in two accuracy classes: class A/AS and class B (see the Chapter on Technical Information). The two classes differ in terms of volume tolerances, with class A being the highest accuracy class and class B being approximately half that of class A. Class AS has the same tolerances as class A, but is designed to permit a more rapid outflow. Volumetric glassware which meets the requirements of the German weights and measures regulations display the conformity marking "DE-M".

Volumetric flasks and cylinders are calibrated to measure the exact amount of fluid they contain ("In"), i.e. up to the ring mark on the vessel. This allows, for example, the desired concentration to be set precisely. Pipettes and burettes are calibrated to measure the amount of fluid delivered ("Ex"). This calibration takes into account surface adhesion to the glass / capillary effects. This is however only the case if the waiting times specified in the product information are observed.









03



> Find your nearest **distributor** on our global network:  
[www.DWK-LifeSciences.com/DURAN/distributors](http://www.DWK-LifeSciences.com/DURAN/distributors)

## ALL INFORMATION AT A GLANCE

## Screen print label for volumetric flasks

		<b>250</b> ±0.15ml In 20°C Made in UK	NS 14/23 A ISO 1042		Volumetric flask, accuracy class A
		<b>250</b> ±0.12ml In 20°C Made in UK	NS 14/23 A ISO 1042		Volumetric flask, accuracy class A, compliant with USP <31>
		<b>250</b> ±0.3ml In 20°C	NS 14/23 B ISO 1042		Volumetric flask, accuracy class B

## Screen print label for pipettes and burettes





Measurement pipette



Full pipette



Burette

	Batch number, e.g. 15.01
	Conformity mark – verifies compliance with the requirements of the German weights and measures regulation and applicable standards.
<b>USP</b>	United States Pharmacopoeia – the product satisfies the requirements specified in USP <31>
<b>250</b>	Nominal volume in mL
<b>±0.12ml</b>	Accuracy tolerance – the deviation of the nominal volume must be no greater than this value which is specified in standards
<b>20°C</b>	Reference temperature – the temperature at which a volumetric instrument must achieve the nominal volume (20°C) stated on it.
<b>A</b>	Accuracy class – denotes the accuracy limit
<b>NS 14/23</b>	Standard taper ground size
<b>ISO 1042</b>	Standard designation
<b>UK</b>	Country of origin
AAA-0001	Individual number (laser-etched onto the base)
DD.MM.YY	Production date (laser-etched onto the base)
<b>In</b>	Calibration based on “In” (poured in volume). The quantity of liquid held corresponds to the volume specification printed on the product.
<b>Ex</b>	Calibration based on discharged volume. The quantity of liquid discharged corresponds to the volume specification printed on the product, e.g. pipettes, burettes. The remaining liquid on the walls of the vessel or in the tip is also taken into consideration.
<b>Ex +30s</b>	Calibrated to deliver after the specified waiting time. In this example 30 seconds. It is important to comply with the waiting time to prevent measurement errors.
<b>10</b> 0.02	Total measurement volume – scale increment is specified below

### 03 VOLUMETRIC GLASSWARE

#### DURAN® Volumetric Flask, class A, USP conformity <31>, USP individual certificate

with scribed graduation mark and ergonomic polyethylene stopper, blue printed image, with USP individual certificate and certificate of conformity

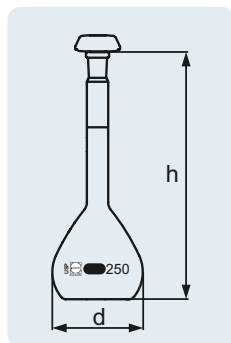

Calibration is based on the poured in volume ("In") at a +20 °C reference temperature. The volume content tolerances conform to accuracy class A, the accuracy limits of the German weights and measures regulations and DIN and ISO specifications.

Typical applications: precise measurement of specified liquid amounts, preparation and storage of standard solutions.

Cat. No.	Capacity (mL)	d (OD) (mm)	h (mm)	Neck	Stopper size	Accuracy limits (mL)	Remark	Pack Unit
24 671 09 58	5 W	22	70	9 ± 1	10/19	0.02	wide neck	2
24 671 10 54	10 W	27	90	9 ± 1	10/19	0.02	wide neck	2
24 671 14 57	25	40	110	9 ± 1	10/19	0.03		2
24 671 17 57	50	50	140	11 ± 1	12/21	0.05		2
24 671 25 56	100	60	170	13 ± 1	14/23	0.08		2
24 671 32 52	200	75	210	15.5 ± 1.5	14/23	0.1		2
24 671 36 55	250	80	220	15.5 ± 1.5	14/23	0.12		2
24 671 44 54	500	100	260	19 ± 2	19/26	0.2		2
24 671 54 59	1 000	125	300	23 ± 2	24/29	0.3		2
24 671 63 52	2 000	160	370	27.5 ± 2.5	29/32	0.5		2

#### DURAN® Volumetric Flask, class A, individual certificate

with scribed graduation mark and ergonomic polyethylene stopper, blue printed image, with individual certificate and certificate of conformity

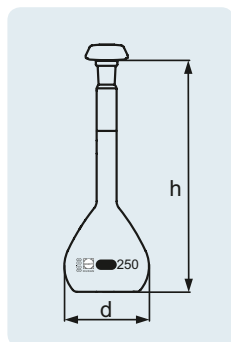

Calibration is based on the poured in volume ("In") at a +20 °C reference temperature. The volume content tolerances conform to accuracy class A, the accuracy limits of the German weights and measures regulations and DIN and ISO specifications.

Typical applications: precise measurement of specified liquid amounts, preparation and storage of standard solutions.

Cat. No.	Capacity (mL)	d (OD) (mm)	h (mm)	Neck	Stopper size	Accuracy limits (mL)	Remark	Pack Unit
24 679 01 51	1	13	65	7 ± 1	7/16	0.025		2
24 679 02 54	2	17	70	7 ± 1	7/16	0.025		2
24 679 09 57	5 W	22	70	9 ± 1	10/19	0.04	wide neck	2
24 679 10 53	10 W	27	90	9 ± 1	10/19	0.04	wide neck	2
24 679 12 59	20	39	110	9 ± 1	10/19	0.04		2
24 679 14 56	25	40	110	9 ± 1	10/19	0.04		2
24 679 17 56	50	50	140	11 ± 1	12/21	0.06		2
24 679 24 52	100	60	170	13 ± 1	12/21	0.1		2
24 679 25 55	100	60	170	13 ± 1	14/23	0.1		2
24 679 32 51	200	75	210	15.5 ± 1.5	14/23	0.15		2
24 679 36 54	250	80	220	15.5 ± 1.5	14/23	0.15		2
24 679 44 53	500	100	260	19 ± 2	19/26	0.25		2
24 679 54 58	1 000	125	300	23 ± 2	24/29	0.4		2
24 679 55 52	1 000 W	125	300	27.5 ± 2.5	29/32	0.6	wide neck	2
24 679 63 51	2 000	160	370	27.5 ± 2.5	29/32	0.6		2
24 679 73 56	5 000	215	475	38 ± 3	34/35	1.2		1

Calibration is based on the poured in volume ("In") at a +20 °C reference temperature. The volume content tolerances conform to accuracy class A, the accuracy limits of the German weights and measures regulations and DIN and ISO specifications.

Typical applications: precise measurement of specified liquid amounts, preparation and storage of standard solutions.

Cat. No.	Capacity (mL)	d (OD) (mm)	h (mm)	Neck	Stopper size	Accuracy limits (mL)	Remark	Pack Unit
24 677 09 55	5 W	22	70	9 ± 1	10/19	0.04	wide neck	2
24 677 10 51	10 W	27	90	9 ± 1	10/19	0.04	wide neck	2
24 677 12 57	20	39	110	9 ± 1	10/19	0.04		2
24 677 14 54	25	40	110	9 ± 1	10/19	0.04		2
24 677 17 54	50	50	140	11 ± 1	12/21	0.06		2
24 677 24 59	100	60	170	13 ± 1	12/21	0.1		2
24 677 25 53	100	60	170	13 ± 1	14/23	0.1		2
24 677 32 58	200	75	210	15.5 ± 1.5	14/23	0.15		2
24 677 36 52	250	80	220	15.5 ± 1.5	14/23	0.15		2
24 677 44 51	500	100	260	19 ± 2	19/26	0.25		2
24 677 54 56	1 000	125	300	23 ± 2	24/29	0.4		2
24 677 63 58	2 000	160	370	27.5 ± 2.5	29/32	0.6		2

### DURAN® Volumetric Flask, class A, amber, individual certificate

with scribed graduation mark and ergonomic polyethylene stopper, white printed image, with individual certificate and certificate of conformity

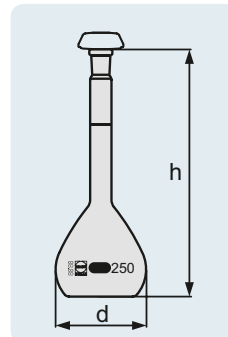

Calibration is based on the poured in volume ("In") at a +20 °C reference temperature. The volume content tolerances conform to accuracy class A, the accuracy limits of the German weights and measures regulations and DIN and ISO specifications.

Typical applications: precise measurement of specified liquid amounts, preparation and storage of standard solutions.

Cat. No.	Capacity (mL)	d (OD) (mm)	h (mm)	Neck	Stopper size	Accuracy limits (mL)	Remark	Pack Unit
24 678 01 59	1	13	65	7 ± 1	7/16	0.025		2
24 678 02 53	2	17	70	7 ± 1	7/16	0.025		2
24 678 09 56	5 W	22	70	9 ± 1	10/19	0.04	wide neck	2
24 678 10 52	10 W	27	90	9 ± 1	10/19	0.04	wide neck	2
24 678 12 58	20	39	110	9 ± 1	10/19	0.04		2
24 678 14 55	25	40	110	9 ± 1	10/19	0.04		2
24 678 17 55	50	50	140	11 ± 1	12/21	0.06		2
24 678 24 51	100	60	170	13 ± 1	12/21	0.1		2
24 678 25 54	100	60	170	13 ± 1	14/23	0.1		2
24 678 32 59	200	75	210	15.5 ± 1.5	14/23	0.15		2
24 678 36 53	250	80	220	15.5 ± 1.5	14/23	0.15		2
24 678 44 52	500	100	260	19 ± 2	19/26	0.25		2
24 678 54 57	1 000	125	300	23 ± 2	24/29	0.4		2
24 678 55 51	1 000 W	125	300	27.5 ± 2.5	29/32	0.6	wide neck	2
24 678 63 59	2 000	160	370	27.5 ± 2.5	29/32	0.6		2
24 678 73 55	5 000	215	475	38 ± 3	34/35	1.2		1

### DURAN® Volumetric Flask, class A, batch certificate

with scribed graduation mark and ergonomic polyethylene stopper, blue printed image, with batch certificate and certificate of conformity

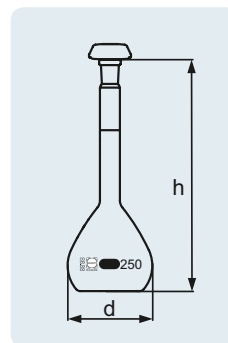

### 03 VOLUMETRIC GLASSWARE

#### DURAN® Volumetric Flask, class A, amber, batch certificate

with scribed graduation mark and ergonomic polyethylene stopper, white printed image, with batch certificate and certificate of conformity

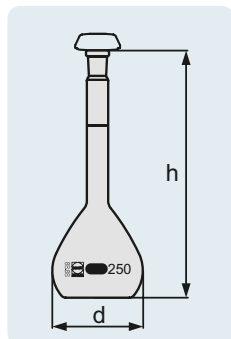

ISO  
1042

A  
121 °C

Calibration is based on the poured in volume ("In") at a +20 °C reference temperature. The volume content tolerances conform to accuracy class A, the accuracy limits of the German weights and measures regulations and DIN and ISO specifications.

Typical applications: precise measurement of specified liquid amounts, preparation and storage of standard solutions.

Cat. No.	Capacity (mL)	d (OD) (mm)	h (mm)	Neck	Stopper size	Accuracy limits (mL)	Remark	Pack Unit
24 676 09 54	5 W	22	70	9 ± 1	10/19	0.04	wide neck	2
24 676 10 59	10 W	27	90	9 ± 1	10/19	0.04	wide neck	2
24 676 12 56	20	39	110	9 ± 1	10/19	0.04		2
24 676 14 53	25	40	110	9 ± 1	10/19	0.04		2
24 676 17 53	50	50	140	11 ± 1	12/21	0.06		2
24 676 24 58	100	60	170	13 ± 1	12/21	0.1		2
24 676 25 52	100	60	170	13 ± 1	14/23	0.1		2
24 676 32 57	200	75	210	15.5 ± 1.5	14/23	0.15		2
24 676 36 51	250	80	220	15.5 ± 1.5	14/23	0.15		2
24 676 44 59	500	100	260	19 ± 2	19/26	0.25		2
24 676 54 55	1 000	125	300	23 ± 2	24/29	0.4		2
24 676 63 57	2 000	160	370	27.5 ± 2.5	29/32	0.6		2

#### DURAN® Volumetric Flask, class A, without certificate of conformity

with scribed graduation mark and octagonal stopper from PE, white printed image, with batch certificate, without certificate of conformity

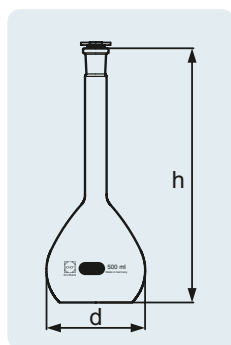

ISO  
1042

A  
121 °C

Calibration is based on the poured in volume ("In") at a +20 °C reference temperature. The volume content tolerances conform to accuracy class A, the accuracy limits of the German weights and measures regulations and DIN and ISO specifications.

Typical applications: precise measurement of specified liquid amounts, preparation and storage of standard solutions.

Cat. No.	Capacity (mL)	d (OD) (mm)	h (mm)	Neck	Stopper size	Accuracy limits (mL)	Pack Unit
21 678 07 04	5	22	70	7 ± 1	7/16	0.025	2
21 678 08 07	10	27	90	7 ± 1	7/16	0.025	2
21 678 12 03	20	39	110	9 ± 1	10/19	0.04	2
21 678 14 09	25	40	110	9 ± 1	10/19	0.04	2
21 678 17 09	50	50	140	11 ± 1	12/21	0.06	2
21 678 24 05	100	60	170	13 ± 1	12/21	0.1	2
21 678 25 08	100	60	170	13 ± 1	14/23	0.1	2
21 678 32 04	200	75	210	15.5 ± 1.5	14/23	0.15	2
21 678 36 07	250	80	220	15.5 ± 1.5	14/23	0.15	2
21 678 44 06	500	100	260	19 ± 2	19/26	0.25	2
21 678 54 02	1 000	125	300	23 ± 2	24/29	0.4	2
21 678 63 04	2 000	160	370	27.5 ± 2.5	29/32	0.6	2
21 678 73 09	5 000	215	475	38 ± 3	34/35	1.2	1

Calibration is based on the poured in volume ("In") at a +20 °C reference temperature. The volume content tolerances conform to accuracy class B, the accuracy limits of the German weights and measures regulations and DIN and ISO specifications.

Typical applications: precise measurement of specified liquid amounts, preparation and storage of standard solutions.

Cat. No.	Capacity (mL)	d (OD) (mm)	h (mm)	Neck	Stopper size	Accuracy limits (mL)	Remark	Pack Unit
24 670 09 57	5 W	22	70	9 ± 1	10/19	0.08	wide neck	2
24 670 10 53	10 W	27	90	9 ± 1	10/19	0.08	wide neck	2
24 670 12 59	20	39	110	9 ± 1	10/19	0.08		2
24 670 14 56	25	40	110	9 ± 1	10/19	0.08		2
24 670 17 56	50	50	140	11 ± 1	12/21	0.12		2
24 670 25 55	100	60	170	13 ± 1	14/23	0.2		2
24 670 32 51	200	75	210	15.5 ± 1.5	14/23	0.3		2
24 670 36 54	250	80	220	15.5 ± 1.5	14/23	0.3		2
24 670 44 53	500	100	260	19 ± 2	19/26	0.5		2
24 670 54 58	1 000	125	300	23 ± 2	24/29	0.8		2
24 670 63 51	2 000	160	370	27.5 ± 2.5	29/32	1.2		2
24 670 73 56	5 000	215	475	38 ± 3	34/35	2.4		1

## DURAN® Volumetric Flask, class B

with scribed graduation mark and ergonomic polyethylene stopper, white printed image

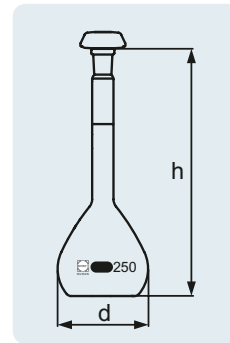

ISO  
1042

A  
121 °C

DURAN® polyethylene stoppers are ergonomically shaped. This ensures that measuring flasks, mixing cylinders and storage bottles can be easily opened and securely closed. Furthermore, a taper with several grooves ensures the perfect seal. The standard taper joint size can be easily and quickly assigned using stopper inserts with different colours.

Cat. No.	d <sub>1</sub> (OD) (mm)	d <sub>2</sub> (OD) (mm)	h (mm)	Colour	Stopper size	Pack Unit
29 205 02 01	29.5	17.5	28	blue	7/16	10
29 205 03 04	32.5	20	32	green	10/19	10
29 205 04 07	36.5	22	35	violet	12/21	10
29 205 06 04	40	25	38	yellow	14/23	10
29 205 07 07	44.5	31	42	blue	19/26	10
29 205 08 01	51.5	38	46	green	24/29	10
29 205 09 04	61	45.5	50	red	29/32	10
29 205 11 03	71	54.5	54	orange	34/45	1
29 205 12 06	81.5	65.5	60	brown	45/40	1

## DURAN® Polyethylene Stoppers

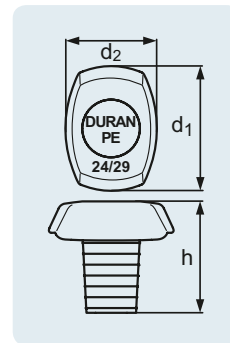

DIN  
12254

Tmax.  
80 °C

The large hexagonal base prevents the cylinder from rolling. The base is equipped with three knobs which increase its stability. The cylinders have uniform wall thickness over the entire measurement range, so wedge errors are avoided. Calibration is based on the poured in volume ("In") at a +20 °C reference temperature. Mixing cylinder accuracy limits conform to DIN and ISO standards. The batch certificates for the mixing cylinders are also available to download online.

Typical applications: diluting solutions, mixing several components with specified proportions.

Cat. No.	Capacity (mL)	d (OD) (mm)	h (mm)	Stopper size	Accuracy limits (mL)	Graduation (mL)	Pack Unit
24 618 08 56	10	14	156	10/19	0.1	0.2	2
24 618 14 58	25	21	190	14/23	0.25	0.5	2
24 618 17 58	50	25	222	19/26	0.5	1	2
24 618 24 54	100	29	287	24/29	0.5	1	2
24 618 36 56	250	39	363	29/32	1	2	2
24 618 44 55	500	53	395	34/35	2.5	5	2
24 618 54 51	1 000	65	500	45/40	5	10	1
24 618 63 53	2 000	85	540	45/40	10	20	1

## DURAN® Mixing Cylinder with hexagonal base, class A

blue scale, ring graduations, with standard ground joint and ergonomic polyethylene stopper, with batch certificate and certificate of conformity

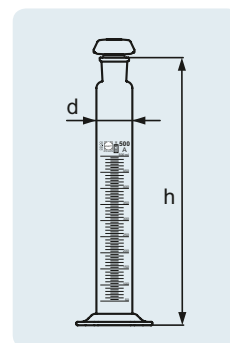

ISO  
4788

A  
121 °C

### DURAN® Mixing Cylinder with hexagonal base, class B

white scale, with graduation, standard ground joint and polypropylene octagonal stopper

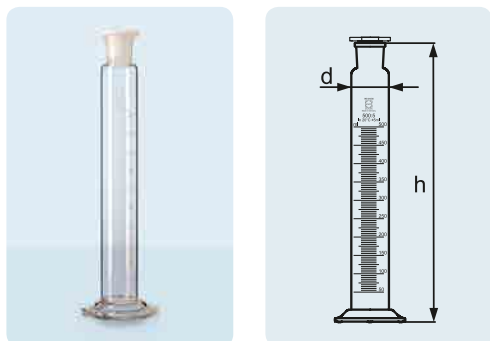

ISO 4788 A 121 °C

The large hexagonal base prevents the cylinder from rolling. The base is equipped with three knobs which increase its stability. The cylinders have uniform wall thickness over the entire measurement range, so wedge errors are avoided. Calibration is based on the poured in volume ("In") at a + 20 °C reference temperature. Mixing cylinder accuracy limits conform to DIN and ISO standards.

Typical applications: diluting solutions, mixing several components with specified proportions.

Cat. No.	Capacity (mL)	d (OD) (mm)	h (mm)	Stopper size	Accuracy limits (mL)	Graduation (mL)	Pack Unit
21 618 08 01	10	14	156	10/19	0.2	0.2	2
21 618 14 03	25	21	190	14/23	0.5	0.5	2
21 618 17 03	50	25	222	19/26	1	1	2
21 618 24 08	100	29	287	24/29	1	1	2
21 618 36 01	250	39	363	29/32	2	2	2
21 618 44 09	500	53	395	34/35	5	5	2
21 618 54 05	1 000	65	500	45/40	10	10	1
21 618 63 07	2 000	85	540	45/40	20	20	1

### DURAN® Measuring Cylinder with hexagonal base, class A

blue scale, ring graduations, with batch certificate and certificate of conformity

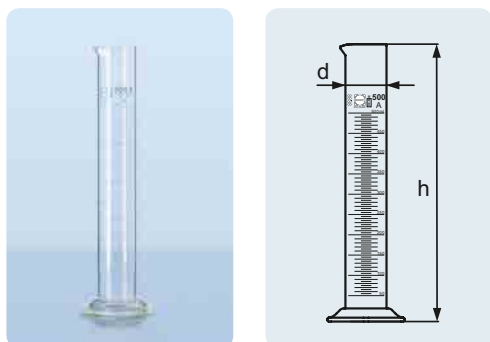

ISO 4788 A 121 °C

The large hexagonal base prevents the cylinder from rolling. The base is equipped with three knobs which increase its stability. The cylinders have uniform wall thickness over the entire measurement range, so wedge errors are avoided. Calibration is based on the poured in volume ("In") at a + 20 °C reference temperature. Measuring cylinder accuracy limits conform to DIN and ISO standards. The batch certificates for the mixing cylinders are also available to download online.

Typical applications: holding and simultaneous measurement of varying liquid amounts.

Cat. No.	Capacity (mL)	d (OD) (mm)	h (mm)	Accuracy limits (mL)	Graduation (mL)	Pack Unit
21 390 07 01	5	12	112	0.05	0.1	2
21 390 08 04	10	14	137	0.1	0.2	2
21 390 14 06	25	21	167	0.25	0.5	2
21 390 17 06	50	25	196	0.5	1	2
21 390 24 02	100	29	256	0.5	1	2
21 390 36 04	250	39	331	1	2	2
21 390 44 03	500	53	360	2.5	5	2
21 390 54 08	1 000	65	460	5	10	1
21 390 63 01	2 000	85	500	10	20	1

The large hexagonal base prevents the cylinder from rolling. The base is equipped with three knobs which increase its stability. The cylinders have uniform wall thickness over the entire measurement range, so wedge errors are avoided. Calibration is based on the poured in volume ("In") at a +20 °C reference temperature. Measuring cylinder accuracy limits conform to DIN and ISO standards (class B).

Typical applications: holding and simultaneous measurement of varying liquid amounts.

Cat. No.	Capacity (mL)	d (OD) (mm)	h (mm)	Accuracy limits (mL)	Graduation (mL)	Pack Unit
21 396 07 07	5	12	112	0.1	0.1	2
21 396 08 01	10	14	137	0.2	0.2	2
21 396 14 03	25	21	167	0.5	0.5	2
21 396 17 03	50	25	196	1	1	2
21 396 24 08	100	29	256	1	1	2
21 396 36 01	250	39	331	2	2	2
21 396 44 09	500	53	360	5	5	2
21 396 54 05	1 000	65	460	10	10	1
21 396 63 07	2 000	85	500	20	20	1

### DURAN® Measuring Cylinder with hexagonal base, class B

white scale, with graduation

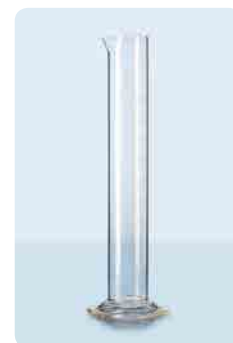
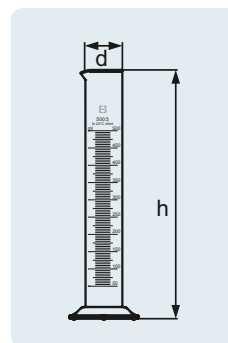

ISO  
4788

A  
121 °C

The large hexagonal base prevents the cylinder from rolling. The base is equipped with three knobs which increase its stability. The cylinders have uniform wall thickness over the entire measurement range, so wedge errors are avoided. Calibration is based on the poured in volume ("In") at a +20 °C reference temperature. Measuring cylinder accuracy limits conform to DIN and ISO standards (class B).

Typical applications: holding and simultaneous measurement of varying liquid amounts.

Cat. No.	Capacity (mL)	d (OD) (mm)	h (mm)	Accuracy limits (mL)	Graduation (mL)	Pack Unit
21 395 08 09	10	21	90	0.2	1	2
21 395 14 02	25	25	115	0.5	1	2
21 395 17 02	50	29	145	1	2	2
21 395 24 07	100	39	165	1	2	2
21 395 36 09	250	54	195	2	5	2
21 395 44 08	500	65	250	5	10	2
21 395 54 04	1 000	85	285	10	20	1
21 395 63 06	2 000	105	340	20	50	1

### DURAN® Measuring Cylinder with hexagonal base, class B, graduated low form

white scale, with graduation

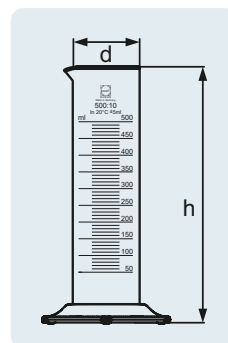

ISO  
4788

A  
121 °C

USP  
Standard

### Measuring Pipette from Soda-lime Glass, class AS, type 1

blue printed image, Drain-out, zero at top, with main graduations as circular divisions and cotton plug, with certificate of conformity and With batch certificate

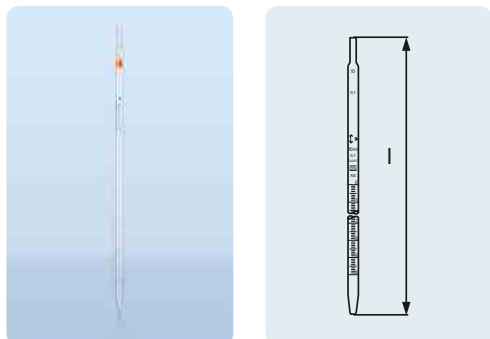

ISO  
835

Numbering from the top down. Calibration is based on the poured out volume ("Ex") at a +20 °C reference temperature. Due to the scale, variable volumes can be held and then dispensed in the same or differing increments.

Typical applications: accurate measurement and decanting of liquids.

Cat. No.	Capacity (mL)	l (mm)	Accuracy limits (mL)	Graduation (mL)	Colour code DIN 12621	Pack Unit
23 346 06 06	0.5	360	0.006	0.01	3 x yellow	12
23 346 11 05	1	360	0.007	0.01	2 x yellow	12
23 346 16 02	2	360	0.01	0.02	2 x black	12
23 346 23 07	5	360	0.03	0.05	2 x red	12
23 346 29 07	10	360	0.05	0.1	2 x orange	12
23 346 32 09	20	360	0.1	0.1	3 x yellow	6
23 346 34 06	25	450	0.1	0.1	2 x white	6
23 346 36 03	50	450	0.2	0.2	2 x black	6

### Measuring Pipette from Soda-lime Glass, class AS, type 2

blue inscription, Blow-out, zero at bottom, graduated to tip (total delivery), with main graduations as circular divisions and cotton plug, with certificate of conformity and batch certificate

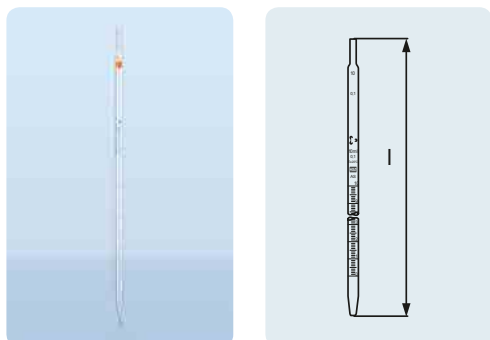

ISO  
835

Numbering: zero at bottom. Calibration is based on the poured out volume ("Ex") at a +20 °C reference temperature. Due to the scale, variable volumes can be held and then dispensed in the same or differing increments.

Typical applications: accurate measurement and decanting of liquids.

Cat. No.	Capacity (mL)	l (mm)	Accuracy limits (mL)	Graduation (mL)	Colour code DIN 12621	Pack Unit
23 348 06 08	0.5	360	0.006	0.01	2 x yellow	12
23 348 11 07	1	360	0.007	0.01	1 x yellow	12
23 348 16 04	2	360	0.01	0.02	1 x black	12
23 348 23 09	5	360	0.03	0.05	1 x red	12
23 348 29 09	10	360	0.05	0.1	1 x orange	12
23 348 32 02	20	360	0.1	0.1	2 x yellow	6
23 348 34 08	25	450	0.1	0.1	1 x white	6
23 348 36 05	50	450	0.2	0.2	1 x black	6

Numbering: zero at bottom. Calibration is based on the poured out volume ("Ex") at a +20 °C reference temperature. Due to the scale, variable volumes can be held and then dispensed in the same or differing increments.

Typical applications: accurate measurement and decanting of liquids.

Cat. No.	Capacity (mL)	l (mm)	Accuracy limits (mL)	Graduation (mL)	Colour code DIN 12621	Pack Unit
23 347 06 07	0.5	360	0.006	0.01	2 x yellow	12
23 347 11 06	1	360	0.007	0.01	1 x yellow	12
23 347 16 03	2	360	0.01	0.02	1 x black	12
23 347 23 08	5	360	0.03	0.05	1 x red	12
23 347 29 08	10	360	0.05	0.1	1 x orange	12
23 347 32 01	20	360	0.1	0.1	2 x yellow	6
23 347 34 07	25	450	0.1	0.1	1 x white	6
23 347 36 04	50	450	0.2	0.2	1 x black	6

### Measuring Pipette from Soda-lime Glass, class AS, type 2

brown inscription, Blow-out, zero at bottom, graduated to tip (total delivery), with main graduations as circular divisions and cotton plug, with certificate of conformity and batch certificate

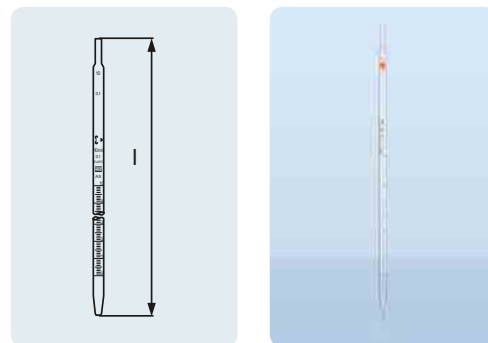

ISO  
835

Numbering from the top down. Calibration is based on the poured out volume ("Ex") at a +20 °C reference temperature. Due to the scale, variable volumes can be held and then dispensed in the same or differing increments.

Typical applications: accurate measurement and decanting of liquids.

Cat. No.	Capacity (mL)	l (mm)	Accuracy limits (mL)	Graduation (mL)	Colour code DIN 12621	Pack Unit
23 349 06 09	0.5	360	0.006	0.01	2 x yellow	12
23 349 11 08	1	360	0.007	0.01	1 x yellow	12
23 349 16 05	2	360	0.01	0.02	1 x black	12
23 349 23 01	5	360	0.03	0.05	1 x red	12
23 349 29 01	10	360	0.05	0.1	1 x orange	12
23 349 32 03	20	360	0.1	0.1	2 x yellow	6
23 349 34 09	25	450	0.1	0.1	1 x white	6
23 349 36 06	50	450	0.2	0.2	1 x black	6

### Measuring Pipette from Soda-lime Glass, class AS, type 3

blue inscription, Blow-out, zero at top, graduated to tip (total delivery), with main graduations as circular divisions and cotton plug, with certificate of conformity and batch certificate

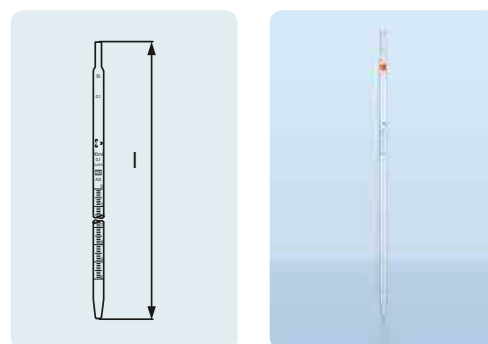

ISO  
835

### Measuring Pipette from Soda-lime Glass, class AS, type 3

Brown diffusion print, blow-out, zero at top, with ring graduations, with cotton plug, with batch certificate and certificate of conformity

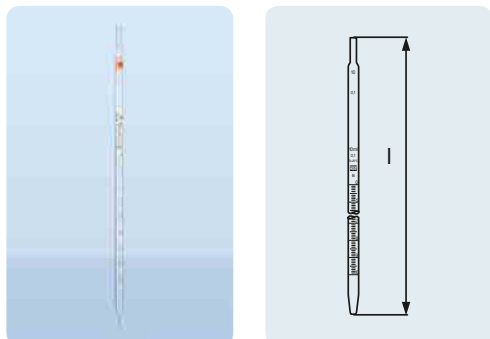

ISO  
835

Numbering from the top down. Due to the scale, variable volumes can be held and then dispensed in the same or differing increments.

Typical applications: accurate measurement and decanting of liquids.

Cat. No.	Capacity (mL)	l (mm)	Accuracy limits (mL)	Graduation (mL)	Colour code DIN 12621	Pack Unit
24 345 11 09	1	360	0.007	0.01	1 x yellow	12
24 345 17 09	2	360	0.01	0.02	1 x black	12
24 345 23 02	5	360	0.03	0.05	1 x red	12
24 345 29 02	10	360	0.05	0.1	1 x orange	12
24 345 34 01	25	450	0.1	0.1	1 x white	12

### Measuring Pipette from Soda-lime Glass, class B, type 1

Brown diffusion print, drain-out, zero at top, graduated, with cotton plug

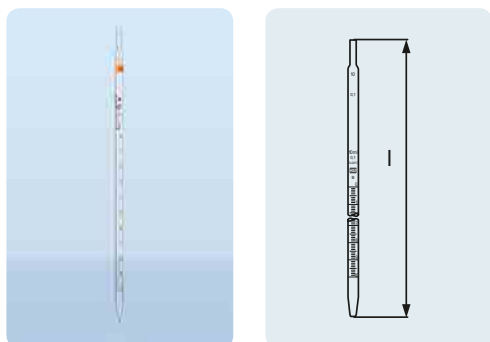

ISO  
835

Numbering from the top down. Calibration is based on the poured out volume ("Ex") at a +20 °C reference temperature. Due to the scale, variable volumes can be held and then dispensed in the same or differing increments.

Typical applications: accurate measurement and decanting of liquids.

Cat. No.	Capacity (mL)	l (mm)	Accuracy limits (mL)	Graduation (mL)	Colour code DIN 12621	Remark	Pack Unit
24 343 01 02	0.1	360	0.01	0.001	3 x green	Non-ISO size, calibrated to contain ("Ex").	12
24 343 03 08	0.2	360	0.01	0.001	3 x blue	Non-ISO size, calibrated to contain ("Ex").	12
24 343 06 08	0.5	360	0.008	0.01	3 x yellow		12
24 343 11 07	1	360	0.008	0.01	2 x yellow		12
24 343 16 04	2	360	0.015	0.02	2 x black		12
24 343 23 09	5	360	0.04	0.05	2 x red		12
24 343 29 09	10	360	0.08	0.1	2 x orange		12
24 343 34 08	25	450	0.15	0.1	2 x white		12

Numbering from the top down. Calibration is based on the poured out volume ("Ex") at a +20 °C reference temperature. Due to the scale, variable volumes can be held and then dispensed in the same or differing increments.

Typical applications: accurate measurement and decanting of liquids.

Cat. No.	Capacity (mL)	l (mm)	Accuracy limits (mL)	Graduation (mL)	Colour code DIN 12621	Remark	Pack Unit
24 344 01 03	0.1	360	0.01	0.001	2 x green	Calibrated to contain ("Ex").	12
24 344 03 09	0.2	360	0.01	0.001	2 x blue	Calibrated to contain ("Ex").	12
24 344 06 09	0.5	360	0.008	0.01	2 x yellow		12
24 344 11 08	1	360	0.008	0.01	1 x yellow		12
24 344 16 05	2	360	0.015	0.02	1 x black		12
24 344 23 01	5	360	0.04	0.05	1 x red		12
24 344 29 01	10	360	0.08	0.1	1 x orange		12
24 344 34 09	25	450	0.15	0.1	1 x white		12

### Measuring Pipette from soda-lime glass, class B, type 3

Brown diffusion print, blow-out, zero at top, graduated, with cotton plug

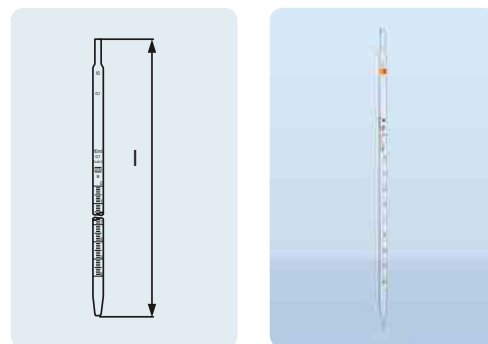

ISO  
835

Calibrated to measure and discharge a single volume ("Ex") at a +20 °C reference temperature. Calibrated to measure and discharge a single volume.

Typical applications: accurate measurement and decanting of liquids.

Cat. No.	Capacity (mL)	l (mm)	Accuracy limits (mL)	Colour code DIN 12621	Remark	Pack Unit
23 339 00 51	0.5	300	0.005	2 x black	No bulb.	12
23 339 01 05	1	325	0.008	1 x blue	No bulb.	12
23 339 02 08	2	350	0.01	1 x orange		12
23 339 03 02	3	350	0.01	1 x black		6
23 339 04 05	4	410	0.015	2 x red		6
23 339 05 08	5	410	0.015	1 x white		6
23 339 06 02	6	410	0.015	2 x orange		6
23 339 07 05	7	410	0.015	2 x green		6
23 339 08 08	8	450	0.02	1 x blue		6
23 339 09 02	9	450	0.02	1 x black		6
23 339 10 07	10	450	0.02	1 x red		6
23 339 15 04	15	520	0.03	1 x green		6
23 339 20 03	20	520	0.03	1 x yellow		6
23 339 25 09	25	530	0.03	1 x blue		6
23 339 30 08	30	530	0.03	1 x black		6
23 339 40 04	40	550	0.05	1 x white		6
23 339 50 09	50	550	0.05	1 x red		6
23 339 00 02	100	600	0.08	1 x yellow		6

### Full Pipette from Soda-lime Glass, class AS

blue inscription, with certificate of conformity and batch certificate

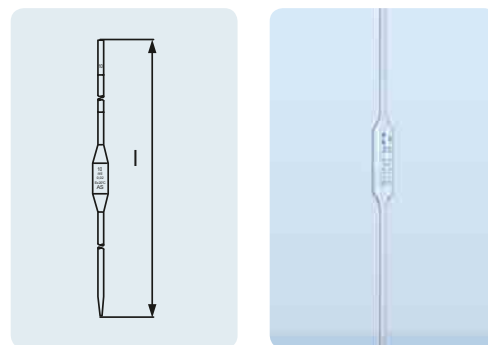

ISO  
648

### Bulb Pipette from Soda-lime Glass, class AS

brown diffusion print, with batch certificate and certificate of conformity

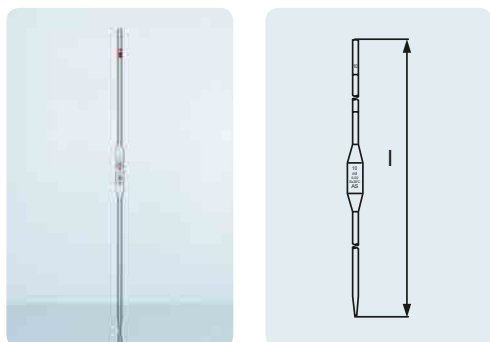

ISO  
648

Calibrated to measure and discharge a single volume ("Ex") at a +20 °C reference temperature. Calibrated to measure and discharge a single volume.

Typical applications: accurate measurement and decanting of liquids.

Cat. No.	Capacity (mL)	l (mm)	Accuracy limits (mL)	Colour code DIN 12621	Remark	Pack Unit
24 338 01 09	1	325	0.008	1 x blue	No bulb.	12
24 338 02 03	2	350	0.01	1 x orange		12
24 338 07 09	5	410	0.015	1 x white		12
24 338 08 03	10	450	0.02	1 x red		12
24 338 12 08	20	520	0.03	1 x yellow		6
24 338 14 05	25	530	0.03	1 x blue		6
24 338 17 05	50	550	0.05	1 x red		6
24 338 24 01	100	600	0.08	1 x yellow		6

### Bulb Pipette from Soda-lime Glass, class B

Brown diffusion print

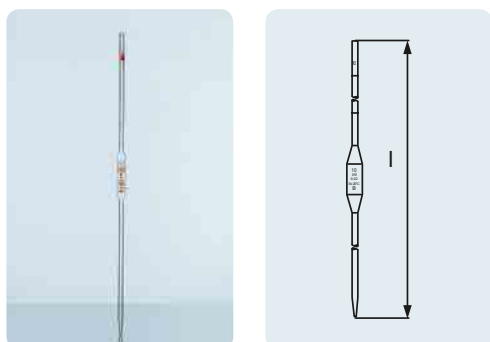

ISO  
648

Calibration is based on the poured out volume ("Ex") at a +20 °C reference temperature. Calibrated to measure and discharge a single volume.

Typical applications: accurate measurement and decanting of liquids.

Cat. No.	Capacity (mL)	l (mm)	Accuracy limits (mL)	Colour code DIN 12621	Remark	Pack Unit
24 337 01 08	1	325	0.01	1 x blue	No bulb.	12
24 337 02 02	2	350	0.015	1 x orange		12
24 337 07 08	5	410	0.02	1 x white		12
24 337 08 02	10	450	0.03	1 x red		12
24 337 12 07	20	520	0.05	1 x yellow		6
24 337 14 04	25	530	0.05	1 x blue		6
24 337 17 04	50	550	0.08	1 x red		6
24 337 24 09	100	600	0.12	1 x yellow		6

With Schellbach stripe and main graduations as circular divisions. Calibration is based on the poured out volume ("Ex") at a +20 °C reference temperature. Volume content tolerances conform to DIN.

Typical application: titrations

Cat. No.	Capacity (mL)	h (mm)	Accuracy limits (mL)	Graduation (mL)	Pack Unit
24 329 27 04	10	820	0.02	0.02	2
24 329 33 06	25	820	0.03	0.05	2
24 329 36 06	50	820	0.05	0.1	2
24 329 39 06	100	870	0.1	0.2	2

### DURAN® Burette with Schellbach stripe and glass blue, class AS

with straight standard ground stopcock, 30 seconds waiting time, with batch certificate and certificate of conformity

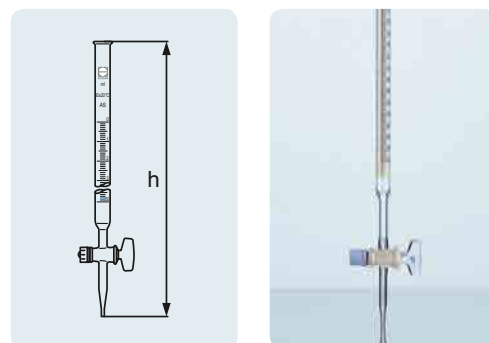

With Schellbach stripe and main graduations as circular divisions. Calibration is based on the poured out volume ("Ex") at a +20 °C reference temperature. Volume content tolerances conform to DIN.

Typical application: titrations

Cat. No.	Capacity (mL)	h (mm)	Accuracy limits (mL)	Graduation (mL)	Pack Unit
24 330 27 02	10	820	0.02	0.02	2
24 330 33 04	25	820	0.03	0.05	2
24 330 36 04	50	820	0.05	0.1	2
24 330 39 04	100	870	0.1	0.2	2

### DURAN® Burette with Schellbach stripe and PTFE key, class AS

with straight standard ground stopcock, 30 seconds waiting time, with batch certificate and certificate of conformity

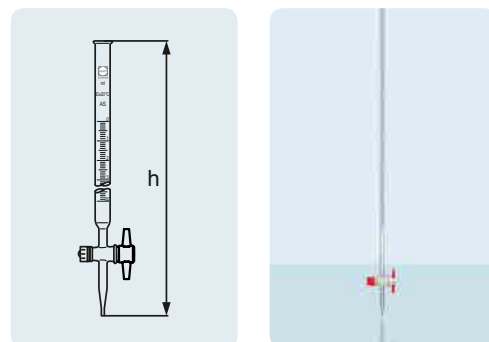

### 03 VOLUMETRIC GLASSWARE

#### DURAN® Burette Amber, with glass key, class AS

with straight standard ground stopcock, white inscription, waiting time: 30 seconds, with batch certificate and certificate of conformity

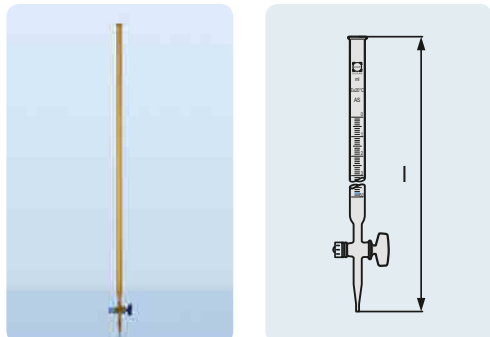

ISO  
385

A  
121 °C

With main graduations as circular divisions. Calibration is based on the poured out volume ("Ex") at a +20 °C reference temperature. Volume content tolerances conform to DIN.

Typical application: titrations.

Cat. No.	Capacity (mL)	l (mm)	Accuracy limits (mL)	Graduation (mL)	Pack Unit
24 326 27 01	10	820	0.02	0.02	2
24 326 33 03	25	820	0.03	0.05	2
24 326 36 03	50	820	0.05	0.1	2
24 326 39 03	100	870	0.1	0.2	2

#### DURAN® Burette Amber, with PTFE key, class AS

with straight standard ground stopcock, white inscription, waiting time: 30 seconds, with batch certificate and certificate of conformity

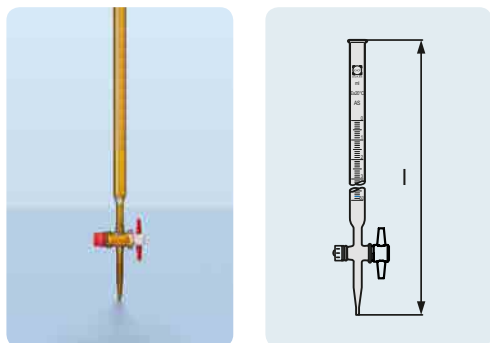

ISO  
385

A  
121 °C

With main graduations as circular divisions. Calibration is based on the poured out volume ("Ex") at a +20 °C reference temperature. Volume content tolerances conform to DIN.

Typical application: titrations.

Cat. No.	Capacity (mL)	l (mm)	Accuracy limits (mL)	Graduation (mL)	Pack Unit
24 336 27 08	10	820	0.02	0.02	2
24 336 33 01	25	820	0.03	0.05	2
24 336 36 01	50	820	0.05	0.1	2
24 336 39 01	100	870	0.1	0.2	2

Calibration is based on the poured out volume ("Ex") at a +20 °C reference temperature. Volume content tolerances conform to DIN and ISO. The Class B accuracy limit is roughly one and a half times wider than for Class AS. The tolerances are thus more strict than specified by DIN.

Typical application: titrations.

Cat. No.	Capacity (mL)	h (mm)	Accuracy limits (mL)	Graduation (mL)	Remark	Pack Unit
24 328 27 03	10	820	0.03	0.02		2
24 328 33 05	25	820	0.04	0.05		2
24 328 36 05	50	820	0.08	0.1		2
24 328 39 05	100	870	0.15	0.2	Non-DIN/ISO size.	2

### DURAN® Burette, class B

with straight standard ground stopcock

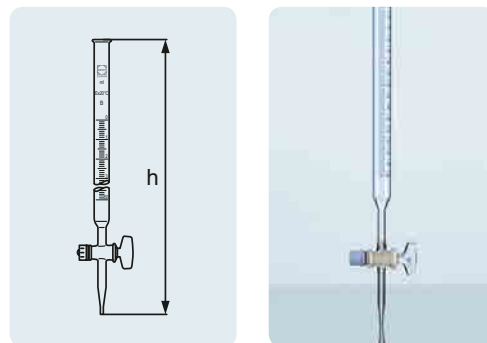

With Schellbach stripe and main graduations as circular divisions. Calibration is based on the poured out volume („Ex“) at a +20 °C reference temperature. Volume content tolerances conform to DIN.

Typical application: titrations.

Cat. No.	Capacity (mL)	h (mm)	Accuracy limits (mL)	Graduation (mL)	Pack Unit
24 320 11 08	1	475	0.01	0.01	1
24 320 16 05	2	550	0.01	0.01	1
24 320 22 07	5	700	0.01	0.02	1

### DURAN® Micro-Burette with Schellbach stripe and glass key, class AS

with straight standard ground stopcock, 30 seconds waiting time, with batch certificate and certificate of conformity

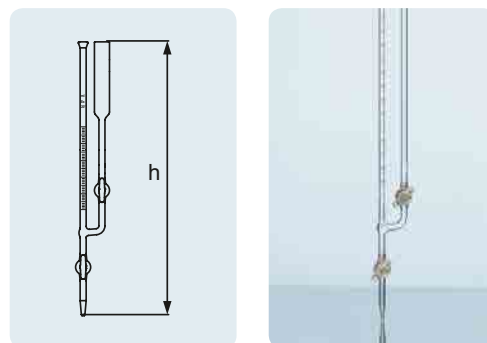

### 03 VOLUMETRIC GLASSWARE

#### DURAN® Micro-Burette with Schellbach stripe and PTFE key, class AS

with straight standard ground stopcock, 30 seconds waiting time, with batch certificate and certificate of conformity

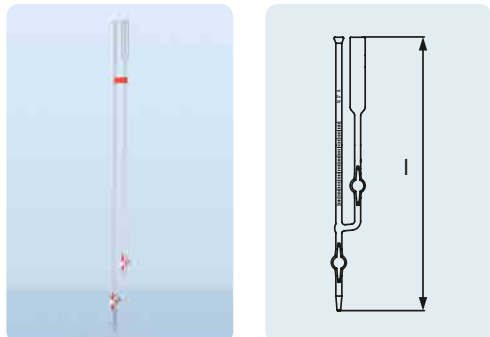

ISO  
385

A  
121 °C

With Schellbach stripe and main graduations as circular divisions. Calibration is based on the poured out volume („Ex“) at a +20 °C reference temperature. Volume content tolerances conform to DIN.

Typical application: titrations.

Cat. No.	Capacity (mL)	l (mm)	Accuracy limits (mL)	Graduation (mL)	Pack Unit
24 321 11 09	1	475	0.01	0.01	2
24 321 16 06	2	550	0.01	0.01	2
24 321 22 08	5	700	0.01	0.02	2
24 321 27 05	10	781	0.02	0.02	2

#### DURAN® Automatic Burette Pellet-type, with glass key, class AS

with Schellbach stripe and glass key, side-positioned standard ground stopcock, 30 seconds waiting time, with batch certificate and certificate of conformity

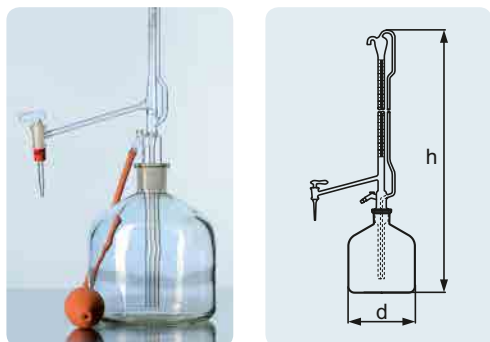

ISO  
385

A  
121 °C

With Schellbach stripe and main graduations as circular divisions, reservoir bottle (2 000 mL) and rubber air pump.

Typical application: titrations.

Cat. No.	Capacity (mL)	h (mm)	Accuracy limits (mL)	Graduation (mL)	Pack Unit
24 318 27 54	10	930	0.02	0.02	1
24 318 33 56	25	930	0.03	0.05	1
24 318 36 56	50	930	0.05	0.1	1

With Schellbach stripe and main graduations as circular divisions, reservoir bottle (2 000 mL) and rubber air pump.

Typical application: titrations.

Cat. No.	Capacity (mL)	h (mm)	Accuracy limits (mL)	Graduation (mL)	Pack Unit
24 317 27 53	10	930	0.02	0.02	1
24 317 33 55	25	930	0.03	0.05	1
24 317 36 55	50	930	0.05	0.1	1

### DURAN® Automatic Burette Pellet-type, with PTFE key, class AS

with Schellbach stripe and PTFE key, side-positioned standard ground stopcock, 30 seconds waiting time, with batch certificate and certificate of conformity

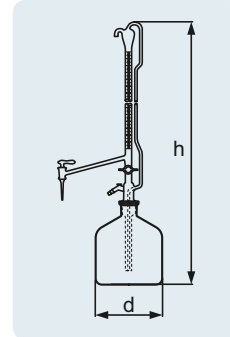

ISO  
385

A  
121 °C

Replacement bottle for automatic burettes.



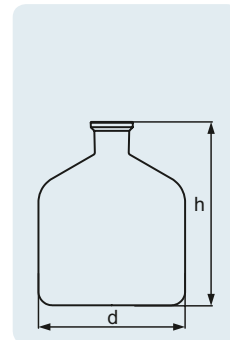

Cat. No.	Capacity (mL)	d (OD) (mm)	h (mm)	Remark	Pack Unit
Neck unground, clear					
21 150 63 03	2 000	160	200	Non-DIN/ISO size.	1
with standard ground NS 29/32, clear					
21 159 63 03	2 000	160	200		1
with standard ground NS 29/32, amber					
21 159 63 69	2 000	160	200		1

### DURAN® Reservoir Bottle



A  
121 °C

## DURAN® RANGE OF VOLUMETRIC FLASKS

Product Range		DURAN® VOLUMETRIC FLASKS, CLEAR			
Accuracy class		Class A			
DURAN® glass volumetric flasks body					
Certificate*		Batch certificate	Batch certificate	Individual certificate	Individual certificate, USP <31> conformity
Certificate of conformity		yes	no	yes	yes
Maximum recommended temperature without affecting accuracy		250 °C	250 °C	250 °C	250 °C
Temperature resistance PE Stopper**		-40 °C to +80 °C	-40 °C to +80 °C	-40 °C to +80 °C	-40 °C to +80 °C
Print Colour		Blue	White	Blue	Blue
mL	Stopper size	With new PE Stopper	With octagonal PE Stopper	With new PE Stopper	With new PE Stopper
1	7 / 16	24 678 01 59	-	24 679 01 51	-
2	7 / 16	24 678 02 53	-	24 679 02 54	-
5	7 / 16	-	21 678 07 04	-	-
5W <sup>1</sup>	10 / 19	24 678 09 56	-	24 679 09 57	24 671 09 58
10	7 / 16	-	21 678 08 07	-	-
10W <sup>1</sup>	10 / 19	24 678 10 52	-	24 679 10 53	24 671 10 54
20	10 / 19	24 678 12 58	21 678 12 03	24 679 12 59	-
25	10 / 19	24 678 14 55	21 678 14 09	24 679 14 56	24 671 14 57
50	12 / 21	24 678 17 55	21 678 17 09	24 679 17 56	24 671 17 57
100	12 / 21	24 678 24 51	21 678 24 05	24 679 24 52	-
100	14 / 23	24 678 25 54	21 678 25 08	24 679 25 55	24 671 25 56
200	14 / 23	24 678 32 59	21 678 32 04	24 679 32 51	24 671 32 52
250	14 / 23	24 678 36 53	21 678 36 07	24 679 36 54	24 671 36 55
500	19 / 26	24 678 44 52	21 678 44 06	24 679 44 53	24 671 44 54
1 000	24 / 29	24 678 54 57	21 678 54 02	24 679 54 58	24 671 54 59
1 000W <sup>1</sup>	29 / 32	24 678 55 51	-	24 679 55 52	-
2 000	29 / 32	24 678 63 59	21 678 63 04	24 679 63 51	24 671 63 52
5 000	34 / 35	24 678 73 55	21 678 73 09	24 679 73 56	-

\* Batch certificates also available online

W<sup>1</sup> = Wide neck

\*\* Chemical resistance at +20 °C

Alcohols, aliphatic	+	Hydrocarbons, aromatic	-
Aldehydes	+	Hydrocarbons, halogenated	-
Alkaline solutions	++	Ketones	+
Esters	+	Acids, dilute or weak	+
Esters	-	Acids, conc. or strong	+
Hydrocarbons, aliphatic	-	Acids, oxidising	-

DURAN® VOLUMETRIC FLASKS, CLEAR		DURAN® VOLUMETRIC FLASKS, AMBER		DURAN® STOPPER PE	OCTAGONAL STOPPER PE
Class B		Class A			
					
–	Batch certificate	Individual certificate	–	–	
no	yes	yes	–	–	
250 °C	250 °C	250 °C	–	–	
–40 °C to +80 °C	–40 °C to +80 °C	–40 °C to +80 °C	–40 °C to +80 °C	–40 °C to +80 °C	
White	White	White	–	–	
With new PE Stopper	With new PE Stopper	With new PE Stopper	Replacement Stopper	Replacement Stopper	
–	–	–	● 29 205 02 01	● 29 204 02 09	
–	–	–	● 29 205 03 04	● 29 204 03 03	
–	–	–	● 29 205 02 01	● 29 204 02 09	
24 670 09 57	24 676 09 54	24 677 09 55	● 29 205 03 04	● 29 204 03 03	
–	–	–	● 29 205 02 01	● 29 204 02 09	
24 670 10 53	24 676 10 59	24 677 10 51	● 29 205 03 04	● 29 204 03 03	
24 670 12 59	24 676 12 56	24 677 12 57	● 29 205 03 04	● 29 204 03 03	
24 670 14 56	24 676 14 53	24 677 14 54	● 29 205 03 04	● 29 204 03 03	
24 670 17 56	24 676 17 53	24 677 17 54	● 29 205 04 07	● 29 204 04 06	
–	24 676 24 58	24 677 24 59	● 29 205 04 07	● 29 204 04 06	
24 670 25 55	24 676 25 52	24 677 25 53	● 29 205 04 07	● 29 204 04 06	
24 670 32 51	24 676 32 57	24 677 32 58	● 29 205 06 04	● 29 204 06 03	
24 670 36 54	24 676 36 51	24 677 36 52	● 29 205 06 04	● 29 204 06 03	
24 670 44 53	24 676 44 59	24 677 44 51	● 29 205 07 07	● 29 204 07 06	
24 670 54 58	24 676 54 55	24 677 54 56	● 29 205 08 01	● 29 204 08 09	
–	–	–	● 29 205 08 01	● 29 204 08 09	
24 670 63 51	24 676 63 57	24 677 63 58	● 29 205 09 04	● 29 204 09 03	
24 670 73 56	–	–	● 29 205 09 04	● 29 204 09 03	
			● 29 205 11 03	● 29 204 11 02	

## DURAN® RANGE OF MEASURING AND MIXING CYLINDERS





Product Range		DURAN® MIXING CYLINDERS	
Accuracy class		Class A	Class B
DURAN® glass cylinder body			
Certificate*		Batch certificate	–
Maximum recommended temperature for drying without affecting accuracy.		250 °C	250 °C
Temperature resistance PE Stopper		–40 °C to +80 °C	–40 °C to +80 °C
Print colour		Blue	White
mL	Stopper size <sup>1</sup>	With new PE Stopper	With octagonal PE Stopper
5	–	–	–
10	10 / 19	24 618 08 56	21 618 08 01
25	14 / 23	24 618 14 58	21 618 14 03
50	19 / 26	24 618 17 58	21 618 17 03
100	24 / 29	24 618 24 54	21 618 24 08
250	29 / 32	24 618 36 56	21 618 36 01
500	34 / 35	24 618 44 55	21 618 44 09
1 000	45 / 40	24 618 54 51	21 618 54 05
2 000	45 / 40	24 618 63 53	21 618 63 07

\*Batch certificates also available online

<sup>1</sup> Valid for mixing cylinders only

	DURAN® MEASURING CYLINDERS		DURAN® MEASURING CYLINDERS	DURAN® SUPER DUTY MEASURING CYLINDERS
	Class A	Class B	Class B	Class B
				
	Batch certificate	-	-	-
	250 °C	250 °C	250 °C	250 °C
	-	-	-	-
	Blue	White	White	White
	21 390 07 01	21 396 07 07	-	-
	21 390 08 04	21 396 08 01	21 395 08 09	-
	21 390 14 06	21 396 14 03	21 395 14 02	-
	21 390 17 06	21 396 17 03	21 395 17 02	-
	21 390 24 02	21 396 24 08	21 395 24 07	21 394 24 06
	21 390 36 04	21 396 36 01	21 395 36 09	21 394 36 08
	21 390 44 03	21 396 44 09	21 395 44 08	21 394 44 07
	21 390 54 08	21 396 54 05	21 395 54 04	21 394 54 03
	21 390 63 01	21 396 63 07	21 395 63 06	-

## RANGE OF BULB AND MEASURING PIPETTES FROM SODA-LIME GLASS

Product Range	BULB PIPETTES			MEASURING PIPETTES	
Accuracy class	Class AS		Class B	Class AS	
Material of the pipettes: soda-lime glass (AR® glass)					
Certificate*	Batch certificate	Batch certificate	–	Batch certificate	
Maximum recommended temperature for drying without affecting accuracy	250 °C	250 °C	250 °C	250 °C	
Print colour	Amber stain graduation	Blue	Amber stain graduation	Amber stain graduation	
mL				TYPE 3	
0.1	–	–	–	–	
0.2	–	–	–	–	
0.5	–	23 339 00 51	–	–	
1	24 338 01 09	23 339 01 05	24 337 01 08	24 345 11 09	
2	24 338 02 03	23 339 02 08	24 337 02 02	24 345 17 09	
3	–	23 339 03 02	–	–	
4	–	23 339 04 05	–	–	
5	24 338 07 09	23 339 05 08	24 337 07 08	24 345 23 02	
6	–	23 339 06 02	–	–	
7	–	23 339 07 05	–	–	
8	–	23 339 08 08	–	–	
9	–	23 339 09 02	–	–	
10	24 338 08 03	23 339 10 07	24 337 08 02	24 345 29 02	
15	–	23 339 15 04	–	–	
20	24 338 12 08	23 339 20 03	24 337 12 07	–	
25	24 338 14 05	23 339 25 09	24 337 14 04	24 345 34 01	
30	–	23 339 30 08	–	–	
40	–	23 339 40 04	–	–	
50	24 338 17 05	23 339 50 09	24 337 17 04	–	
100	24 338 24 01	23 339 00 02	24 337 24 09	–	

TYPE 1 – partial delivery, zero point at the top

TYPE 2 – total delivery, nominal volume at the top

TYPE 3 – total delivery, zero point at the top



\*Batch certificates also available online

AR® glass = registered trademark of SCHOTT AG





MEASURING PIPETTES

Class AS				Class B		
	Batch certificate	Batch certificate	Batch certificate	Batch certificate	–	–
	250 °C	250 °C	250 °C	250 °C	250 °C	250 °C
	Blue	Amber stain graduation	Blue	Blue	Amber stain graduation	Amber stain graduation
	<b>TYPE 1</b>	<b>TYPE 2</b>	<b>TYPE 2</b>	<b>TYPE 3</b>	<b>TYPE 1</b>	<b>TYPE 3</b>
	–	–	–	–	24 343 01 02	24 344 01 03
	–	–	–	–	24 343 03 08	24 344 03 09
	23 346 06 06	23 347 06 07	23 348 06 08	23 349 06 09	24 343 06 08	24 344 06 09
	23 346 11 05	23 347 11 06	23 348 11 07	23 349 11 08	24 343 11 07	24 344 11 08
	23 346 16 02	23 347 16 03	23 348 16 04	23 349 16 05	24 343 16 04	24 344 16 05
	–	–	–	–	–	–
	–	–	–	–	–	–
	23 346 23 07	23 347 23 08	23 348 23 09	23 349 23 01	24 343 23 09	24 344 23 01
	–	–	–	–	–	–
	–	–	–	–	–	–
	–	–	–	–	–	–
	23 346 29 07	23 347 29 08	23 348 29 09	23 349 29 01	24 343 29 09	24 344 29 01
	–	–	–	–	–	–
	23 346 32 09	23 347 32 01	23 348 32 02	23 349 32 03	–	–
	23 346 34 06	23 347 34 07	23 348 34 08	23 349 34 09	24 343 34 08	24 344 34 09
	–	–	–	–	–	–
	–	–	–	–	–	–
	23 346 36 03	23 347 36 04	23 348 36 05	23 349 36 06	–	–
	–	–	–	–	–	–

## DURAN® RANGE OF BURETTES

Product Range	DURAN® BURETTES			
Accuracy class	Class AS			
Material of the burettes: DURAN® glass				
Certificate*	Batch certificate	Batch certificate	Batch certificate	Batch certificate
Max. recommended temperature for drying without affecting accuracy	250 °C	250 °C	250 °C	250 °C
Glass colour	clear glass	amber glass	clear glass	amber glass
Print colour	Blue	White	Blue	White
Schellbach stripe	yes	no	yes	no
mL	Straight glass stopcock	Straight glass stopcock	Straight PTFE stopcock	Straight PTFE stopcock
1	–	–	–	–
2	–	–	–	–
5	–	–	–	–
10	24 329 27 04	24 326 27 01	24 330 27 02	24 336 27 08
25	24 329 33 06	24 326 33 03	24 330 33 04	24 336 33 01
50	24 329 36 06	24 326 36 03	24 330 36 04	24 336 36 01
100	24 329 39 06	24 326 39 03	24 330 39 04	24 336 39 01

\* Batch certificates also available online

DURAN® BURETTES					
		AUTOMATIC BURETTES – PELLET TYPE	MICRO-BURETTES		
	Class B	Class AS			
					
	–	Batch certificate	Batch certificate	Batch certificate	Batch certificate
	250 °C	250 °C	250 °C	250 °C	250 °C
	clear glass	–	–	–	–
	Blue	Blue	Blue	Blue	Blue
	no	yes	yes	yes	yes
	<b>Straight glass stopcock</b>	<b>Lateral glass stopcock</b>	<b>PTFE spindle stopcock, intermediate PTFE stopcock</b>	<b>Straight glass stopcock</b>	<b>Straight PTFE stopcock, intermediate PTFE stopcock</b>
	–	–	–	24 320 11 08	24 321 11 09
	–	–	–	24 320 16 05	24 321 16 06
	–	–	–	24 320 22 07	24 321 22 08
	24 328 27 03	24 318 27 54	24 317 27 53	–	24 321 27 05
	24 328 33 05	24 318 33 56	24 317 33 55	–	–
	24 328 36 05	24 318 36 56	24 317 36 55	–	–
	24 328 39 05	–	–	–	–